

DEVELOPMENT OF LOW PHASE NOISE SMALL FOOT PRINT SURFACE MOUNT VOLTAGE CONTROLLED OSCILLATOR

Ameen Ahmed, Noushad S, Suchitav K, K.R.Suresh Nair, P.K.Radhakrishnan

NeST Research & Development Center,
Plot # 43, CEPZ, Kakkanad
COCHIN-682 030.

Abstract: Recently Voltage Controlled Oscillator (VCO) has emerged as a fascinating candidate to satisfy strong demands in the rapidly growing wireless communication products, test equipment and system development. Modular configuration with low phase noise is the desirable feature to be incorporated in VCOs for their better usage. Here we report development of a low phase noise small foot print (0.5"x0.5"x0.205") voltage controlled oscillator operating in a frequency range of 2.9 to 3.1 GHz for RACON applications. The oscillator is realised as a surface mount unit. The paper gives details on the performance as well as the test procedures.

INTRODUCTION:

Voltage controlled oscillators (VCOs) remain as the basic building block for any of present communication or transmission scheme including cellular mobile telephone, radar systems, etc. Voltage controlled oscillators in commonly used frequency bands are commercially available from many manufacturers. Current development effort is for a Radio beacon (normally known as RACON) system, where the frequency band requirement is from 2.9 to 3.1 GHz. Some manufacturers offer oscillators covering this band, but these are seen to be of wide operating range, which reduces the tuning sensitivity. The system requirement calls for a tuning range of 2.9 to 3.1 GHz with control voltage of 4 Volts. In order to keep low phase noise, special design and layout techniques were used. The successful development of this VCO led to requirement of production of many such units, and thus the developed units have been tested for its characteristics.

The VCO consists of a resonator network, amplifier and output matching network with feed back arrangement as shown in Fig.1.

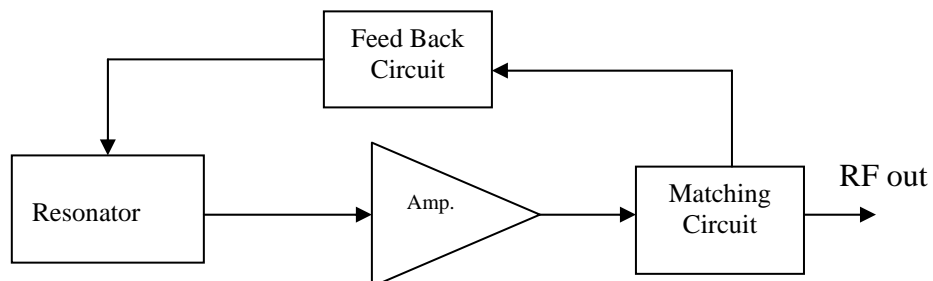

Fig.1 Block Diagram of VCO

The design starts with a set of specifications ,proper selection topology and components. The resonator network consist of a varactor diode .With the applied dc voltage the capacitance of the varactor will be varied ,so also the resonating frequency.

SOME DESIGN CONSIDERATIONS

General design considerations of VCO are Output power level, Output Harmonic level, Tuning Sensitivity, Load pulling, frequency pushing and Phase noise.

Output harmonic level is the measure of VCO energy at harmonics of the oscillation frequency. These harmonics, common at levels below -15 dBc, are generated by non-linear self-limiting of active devices in the oscillator. Oscillators with large amount of excess gain (greater than the amount necessary to offset all losses at resonance) will limit more severely, thereby generating a greater harmonic content in the output level. Here the design is balanced with the need to keep the harmonic levels low with the need for excess gain to ensure oscillator to start-up.

Phase noise in a VCO, relates the noise-sideband level to the carrier-power level, is a measure of short term random frequency fluctuations of a signal. The single-sideband phase noise is given by

$$L(F_m) = 10 \log \left[\frac{1}{2} \left[\left(\frac{F_o}{2 Q_L F_m} \right)^2 + 1 \right] \left(\frac{F_c}{F_m} + 1 \right) \frac{F k T}{P_s} \right]$$

$L(F_m)$ = single-sideband phase noise in dBc/Hz, as a function of offset frequency from the carrier

F_o = output frequency in Hz.

Q_L = loaded resonator Q (resonator tank circuit with active load and all parasitic elements)

F_c = corner frequency in Hz for flicker noise in the active oscillation device.

F_m = offset from the carrier in Hz.

P_s = the active oscillation device's oscillation-signal power, in watts.

F = the active device's in-circuit noise factor (with the resonator tank and all parasitic elements)

k = Boltzmann's constant : $1.38 \times 10^{-23} \text{ J}^0\text{K}$

In this formula, loaded-resonator Q is the dominant design parameter affecting phase noise. Low-noise design dictates that this parameter be maximized to meet tuneability requirements. A high loaded - resonator Q requires the use of resonant-tank components with high unloaded Q. The resonator's loaded Q can easily be less than a tenth of its unloaded Q.

The corner frequency for flicker noise is device dependent; low-noise design demands devices with a low flicker corner. For GaAs devices flicker- noise corner is from two to three orders of magnitude greater than that of Si-bipolar devices. This low flicker-noise corner makes Si-bipolar devices best choice for low-noise oscillator design.

The design was carried out using Eagleware software. The miniature package VCO is fabricated using surface mount technology with gold plated double sided PCB and shielded with solderable tin plated brass cover

TEST METHODS

Fig.2 shows the frequency spectrum of the developed oscillator. Fig.3 shows the photograph of the developed small foot print oscillator.

Tuning Range and Output Power Measurement:- The setup of this measurement is shown in Fig. 4 . V_t is adjusted for different values in the VCO tuning range. The corresponding

frequencies and output power are measured from the spectrum analyzer and power meter respectively. The results are shown in Fig.5 and 6, respectively.

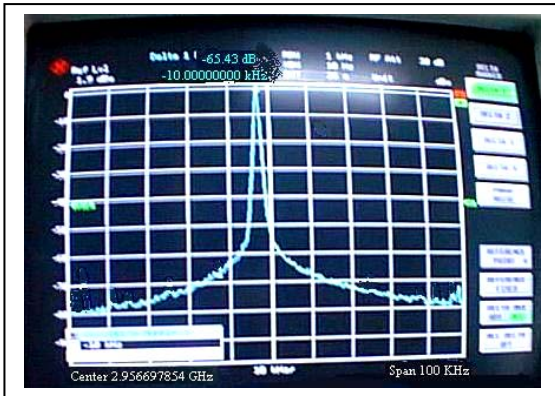

Fig.2 Spectrum of the developed VCO



Fig 3 Photograph of the developed small foot print VCO

(label shows CEPL (Crysind Electronics Pvt Ltd.), a NeST manufacturing company)

Harmonic Content:-The intensity of the second harmonic is measured on the spectrum analyzer and normalised with respect to the fundamental component. The difference is usually in dBc.

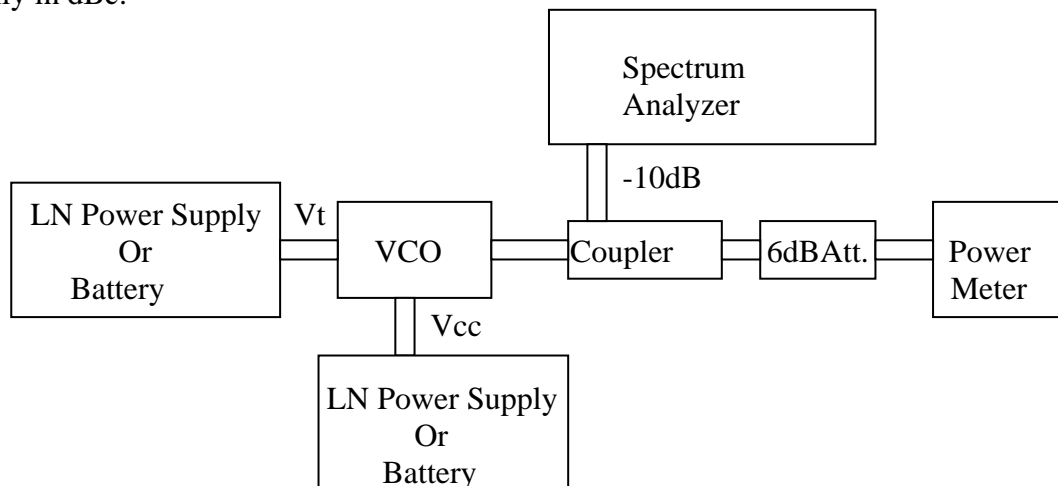

Fig. 4 – Schematic of test set up

Frequency Pulling:- The difference between the frequencies displayed by connecting Open and Short at the output is the total frequency pulling figure and is expressed in MHz. The load consists of a directional coupler, a 6 dB attenuator pad, and an open or short. A sample of energy runs to the spectrum analyzer for frequency measurement. Most of the RF energy runs through the attenuator, is fully reflected from the mismatched load to the oscillator RF port.

Frequency Pushing:- The frequency pushing is determined by varying Vcc by +/-0.5 V at different tuning voltages.

Phase noise:- Battery power supplies should be used for Vcc and tuning voltage (Vt). The tuning voltage is fixed and the VCO output is displayed on the spectrum analyzer. The center frequency, span, and input level are set to observe the noise level below the carrier

at 10kHz offset. Video bandwidth is reduced to smooth the display curve .So it may be accurately read. The span is set for 100 kHz to measure the phase noise at 10 kHz offset.

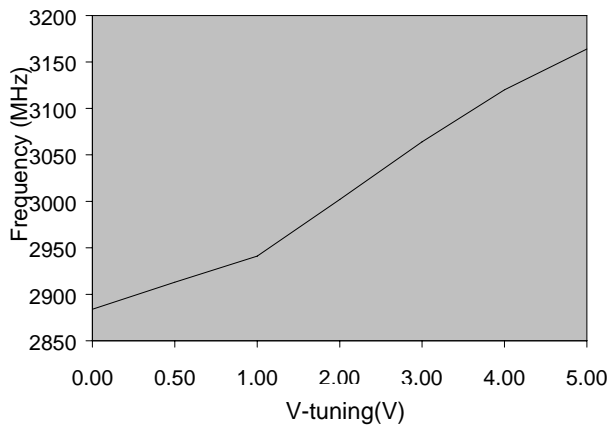

Fig.5 Tuning characteristics

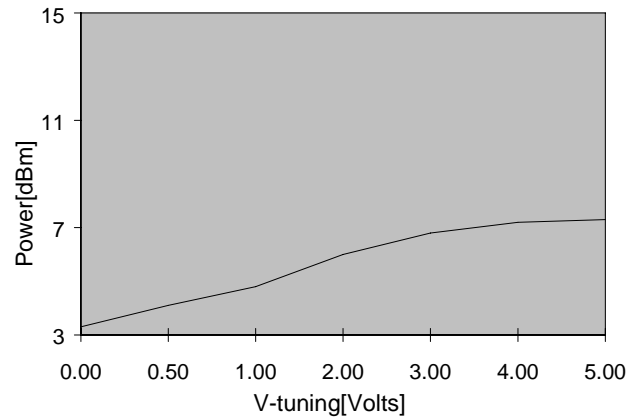

Fig.6 Output Power Characteristics

SPECIFICATIONS ACHIEVED

Frequency	2900-3100 MHz
Tuning Voltage (Vt)	0-4V
Supply Voltage (Vcc)	15V @ 30 mA
Power	6+/-3 dBm
Pulling @ 1.75 VSWR	≤ 15 MHz
Pushing	≤ 5 MHz
Phase noise @ 10 kHz	≤ 94 dBc/Hz
Harmonics	≤ -18 dBc
Tuning Sensitivity	60 MHz/V
Package	0.5'' x 0.5''x 0.205''

CONCLUSION

Here we have reported the development of a custom made voltage controlled oscillator for RACON application. This is a light weight, very compact unit with low phase noise characteristics. The specifications achieved are considered to be best among the commercially available ones. The design takes care of the factors involved in manufacturing environment and production of these units are in progress.

ACKNOWLEDGEMENTS

Authors gratefully acknowledge the effort put by Mr.Juzer Ali in designing similar type of VCOs which has remained as the starting point for this development. The authors thank the help offered by the manufacturing team under the guidance of Mr.G.Neelakandan. This development was possible only due to the support given by Mr.N.Jehangir, Managing Director, NeST Group and Mr.U.M.Shafi, Sr.Vice President. The authors gratefully acknowledge their guidance.

REFERENCES

1. Randall W. Rhea ,'*Oscillator design and computer simulation*', Noble publishing, Georgia ,1995.
2. Vendelin et. al.,'*Microwave circuit design using linear and non-linear techniques*', John Wiley and Sons, New York ,1990.